

# New ways to move.

## SWIFT Lite

SWIFT home lifts represents the future of stylish living, allowing you to move smoothly and swiftly between different floors in your home. Enjoy everyday luxury and the highest level of safety for peace of mind.

SWIFT is specifically designed to be integrated with your home without any of the complicated building works required with traditional elevators. It is safe, smart and silent.

SWIFT Lite is designed to meet the requirements of a limited budget without compromising on style and comfort.

## 100% Battery Driven

Powered by a SWIFT-developed screw and nut drive, SWIFT Lite offers the sweet sound of silence. This machine-room-less lift uses a state-of-the-art 48V battery-driven IPM-SynRM motor with next-generation motor control technology.

Please visit [swiftlifts.com](https://www.swiftlifts.com) for more information.

SWIFT



### EcoDrive

48V battery bank dynamically • Powered by a battery charger. charged when traveling down. • Powered by solar panels. (optional)



### A-rated Energy Consumption

Consumes energy comparable to an A-rated dishwasher at full operation (VDI 4707). Lowest maintenance cost on the market thanks to EcoDrive.



### Easy Installation

All-inclusive lift and shaft package. Floor installation possible. 230V single-phase installation.



### Anti-trap System

Maintains full operation during external power failures. No need to be anxious.



### SWIFT Remote

Always connected for remote monitoring to minimize maintenance and service costs and to optimize functionality.



### Sustainability

Over 90% of components are recyclable.



### Warranty

10-year warranty for the screw and nut drive system. 5-year warranty for the lift (requires a Support and Maintenance package).



### Technical Compliance

Complies with Europe's strictest safety requirements. (European Machinery Directive 2006/42/EC)



# SWIFT Lite

The home lift consists of a L-shaped platform with a floor that moves you up and down. The lift is controlled by classic lift buttons in stainless steel.

## Control Panel Functions

- Classic push buttons
- Overload warning diod
- Emergency stop button
- Alarm button



## Carpets

SWIFT Lite comes with a Vinyl Black carpet as standard. The carpet is a woven vinyl and easy to clean. As an option you can choose a flooring made by the Danish design company Ege Carpets. The yarn is a recycled micro fibre.



Vinyl Black | Standard



Una Micro Grey | Option

## Technical Specifications

**Floors:** 2-6 floors **Travel:** 250 to 15.000 mm

**Speed:** 0.15 m/s (0.3 m/s as an option)

**Power:** 230 V single-phase 6 A (8 A fuse)

**Drive system:** Patent pending screw and nut drive.

**Installation:** Recessed installation 50 mm (in line with the floor) or on top of the floor with a ramp.



## Light

Carrier: White LED

## Doors

- Double glass doors with automatic openers/closers.
- Built-in obstacle detection.

## Handrail

Choose between a black or white handrail.

## Platform wall

Grey white resin board.



## Shaft and Lift Colour

Glass or metal panels. Three colours options.



**Traffic White** | Standard  
RAL 9016

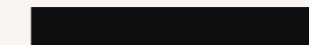

**Jet Black** | Option  
RAL 9005



**Gold** | Option  
RAL 1036

## Lift Parameters

\*Recommended size for the floor opening.

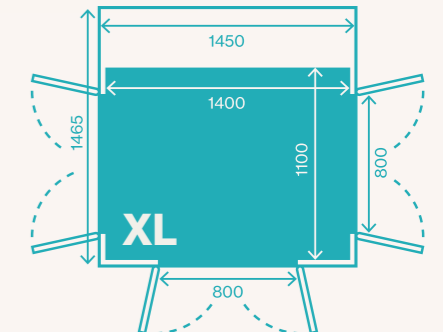
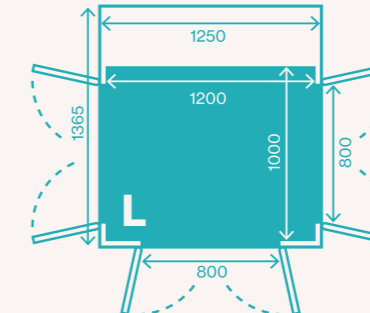
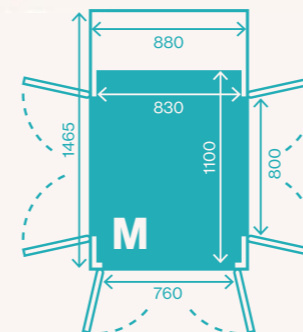
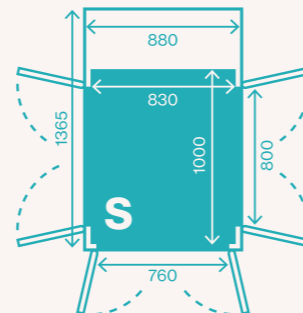
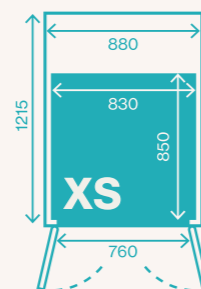
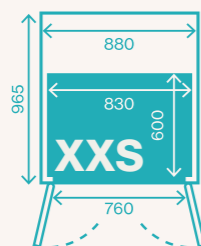

<b>Size:</b>	830x600 mm	830x850 mm	830x1000 mm	830x1100 mm	1200x1000 mm	1400x1100 mm
<b>Rated load:</b>	250 kg / 2 persons	250 kg / 3 persons	250 kg / 3 persons	250 kg / 3 persons	400 kg / 5 persons	400 kg / 5 persons
<b>Hole through floor*</b>	940x1025 mm	940x1275 mm	940x1425 mm	940x1525 mm	1310x1425 mm	1510x1525 mm